

# ILLUSTRATION DRAWING REFERENCE ONLY

REVISIONS			
REV.	DESCRIPTION	DATE	APPROVED
A	SEE ECN 9159	8/7/09	MCS

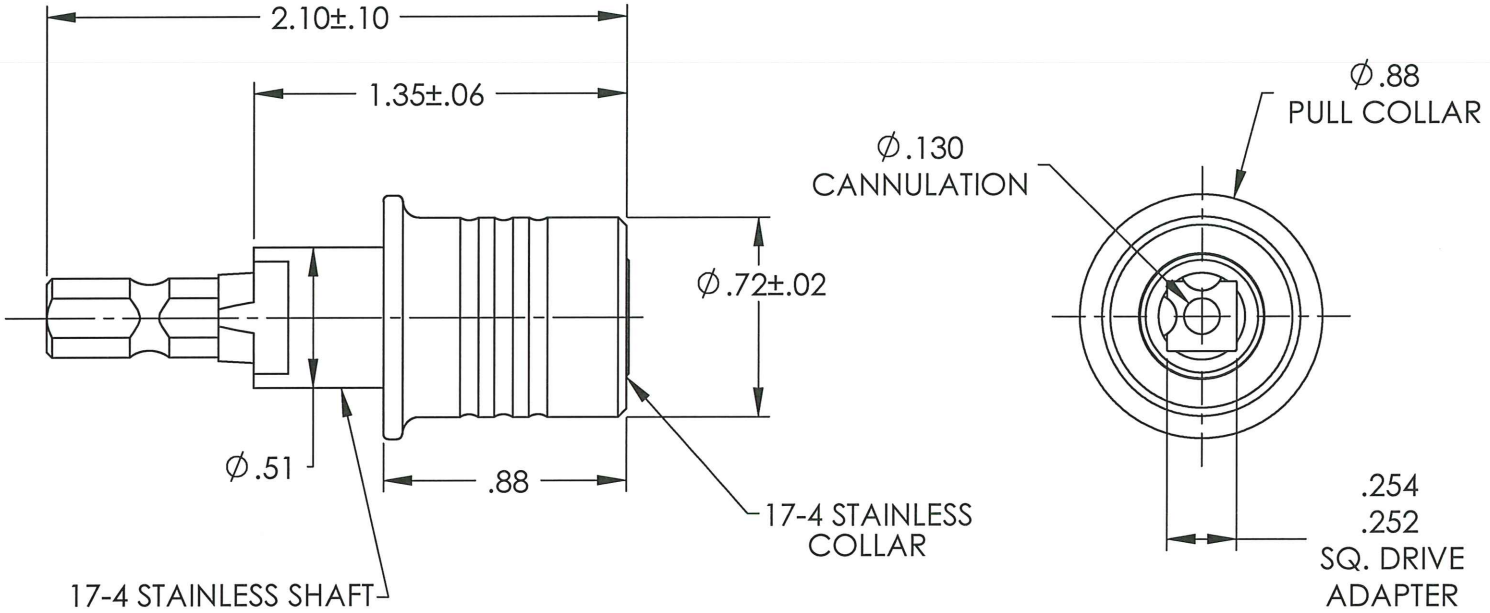

## CUSTOMER APPROVAL

APPROVED BY: \_\_\_\_\_  
DATE: \_\_\_\_\_

THE INFORMATION CONTAINED IN THIS DRAWING IS THE SOLE PROPERTY OF GAUTHIER BIOMEDICAL, INC., ANY REPRODUCTION IN PART OR WHOLE WITHOUT THE WRITTEN PERMISSION OF GAUTHIER BIOMEDICAL, INC. IS PROHIBITED.

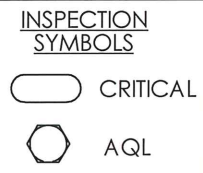

UNLESS OTHERWISE SPECIFIED DIMENSIONS ARE IN INCHES TOLERANCES ARE: FRACTIONS DECIMALS ANGLES ±1/32 .X ±.020 ±1° .XX ±.010 .XXX ±.005 .XXXX ±.0005		 <b>Gauthier Biomedical Inc.</b>	GAUTHIER BIOMEDICAL, INC. 1235 NORTH DAKOTA DRIVE, SUITE G GRAFTON, WI 53024 (262) 546-0010 ph. (262) 546-0011 fax E-mail: engineering@gauthierbiomedical.com	
MATERIAL SEE DETAILS			APPROVALS	DATE
HEAT TREAT		DRAWN	7/2/09	
FINISH		CHECKED	RJB 8/11/09	
PASSIVATE		APPROVED	RJB 8/11/09	
		DO NOT SCALE DRAWING		
		ANODIZE		
		SIZE	REV.	
		A	A	
		PART NUMBER	GA100509	
		SCALE	2:1	
		CAD FILE:	GA100509	
		SHEET	1 OF 1	